

BSP-LA series

BSPO2LA6C

BSPO3LA8D

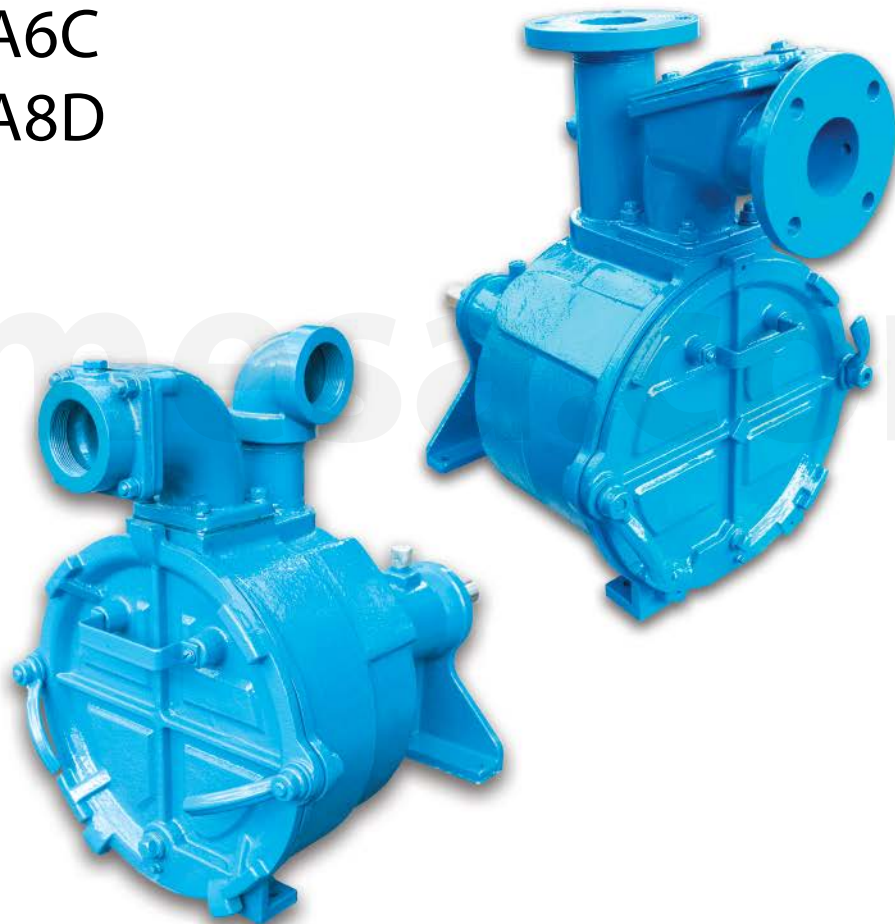

IMPORTANT! - Read all instructions in this manual before operating or servicing a pump.

Before installation, read the following instructions carefully. Failure to follow instruction and safety information could cause serious bodily injury, death and/or property damage. Each Barmesa product is carefully inspected to insure proper performance. Closely following these instructions will eliminate potential operating problems, assuring years of trouble-free service.

⚠ DANGER "Danger" indicates an imminently hazardous situation which, if not avoided, WILL result in death or serious injury.

⚠ WARNING "Warning" indicates an imminently hazardous situation which, if not avoided, MAY result in death or serious injury.

⚠ CAUTION "Caution" indicates a potentially hazardous situation which, if not avoided, MAY result in minor or moderate injury.

IMPORTANT! - Barmesa Pumps is not responsible for losses, injury or death resulting from failure to observe these safety precautions, misuse, abuse or misapplication of pumps or equipment.



ALL RETURNED PRODUCTS MUST BE CLEANED, SANITIZED, OR DECONTAMINATED PRIOR TO SHIPMENT, TO INSURE EMPLOYEES WILL NOT BE EXPOSED TO HEALTH HAZARDS IN HANDLING SAID MATERIAL. ALL APPLICABLE LAWS AND REGULATIONS SHALL APPLY.

⚠ WARNING Installation, wiring, and junction connections must be in accordance with the National Electric Code and all applicable state and local codes. Requirements may vary depending on usage and location.

⚠ WARNING Installation and servicing is to be conducted by qualified personnel only.

⚠ DANGER  Keep clear of suction and discharge openings. Do not insert fingers in pump with power connected; the rotating cutter and/or impeller can cause serious injury.

⚠ WARNING Always wear eye protection when working on pumps. Do not wear loose clothing that may become entangled in moving parts.

⚠ DANGER  Pumps build up heat and pressure during operation. Allow time for pumps to cool before handling or servicing the pump or any accessory items associated with or near the pump.

⚠ DANGER  This pump is *not* intended for use in swimming pools or water installations where human contact with pumped fluid.

⚠ DANGER  Risk of electric shock. To reduce risk of electric shock, always disconnect pump from power source before handling any aspect of the pumping system. **Lock out power and tag.**

⚠ WARNING Do not use these pumps in water over 160° F. Do not exceed manufacturers recommended maximum performance, as this could cause the motor to overheat.

⚠ DANGER  Operation against a closed discharge valve will cause premature bearing and seal failure.

Heat build up on self-priming and end suction pumps may cause dangerous pressures. A high temperature switch or pressure relief valve is recommended to be installed in pump case.

⚠ WARNING Carefully read instruction manuals supplied with motor or engine before operating or servicing.

⚠ DANGER **DO NOT**  pump hazardous material. These pumps are NOT to be installed in locations classified as hazardous in accordance with the National Electric Code, ANSI/NFPA 70.

⚠ CAUTION Pump speed and operating conditions must be within performance range.

⚠ CAUTION **DO NOT** run pump backwards. Make sure that rotation is correct before operating pump.

⚠ WARNING Use proper lifting equipment with adequate capacity to prevent personnel injuries or equipment damage.

⚠ WARNING Before servicing close the suction and discharge valves, vent pump slowly and drain.

⚠ DANGER **DO NOT** operate pump without safety guards in place over rotating parts, which exposed could cause severe injury to personnel.

⚠ WARNING  Pumps constructed with or fitted with bronze/brass may contain lead levels higher than considered safe for potable water systems. Lead is known to cause cancer and birth defects or other reproductive harm. Various government agencies have determined that leaded copper alloys should not be used in potable water applications.

IMPORTANT! - Prior to installation, record Model Number, MFG Date and/or from pump name plate for the future reference.

Model Number: _____

Serial: _____

► **BSPO2LA6C**

DISCHARGE:	2" x 2" NPT, 125 lbs., female flange.
SPHERICAL SLD HNDLG:	1¼"
LIQUID TEMPERATURE:	160 °F (71 °C)
CASING:	Cast iron ASTM A-48 class 30.
IMPELLER:	2 vane, open. Cast iron ASTM A-48 class 30.
SHAFT:	High carbon steel.
END COVER PLATE:	Cast iron ASTM A-48 class 30, removable, full diameter.
VOLUTE / WEAR PLATE:	Cast iron ASTM A-48 class 30, replaceable with external clearance adjustment.
SEAL PLATE:	Alloy steel no. 4140, replaceable.
PEDESTAL:	Cast iron ASTM A-48 class 30
BEARING - PUMP END:	Single ball, radial and thrust load, oil lubricated.
BEARING - DRIVE END:	Single ball, radial and thrust load, oil lubricated.
PEDESTAL AND	
BEARING LUBRICATION:	SAE no. 30 non detergent oil, pedestal includes oil level sight gauges.
SEAL:	Single, mechanical, grease lubricated by self-feeding lubricator. Material: carbon / ceramic / Buna-N.
CHECK VALVE:	Elbow and weights are cast iron ASTM A-48 class 30, neoprene flap valve.
SQUARE RINGS:	Buna-N.
HARDWARE:	Corrosion resistant steel.
PAINT:	Air dry enamel, water based.
OPTIONAL EQUIPMENT:	Flexible coupled assy, with base OSHA guard and electric motor.

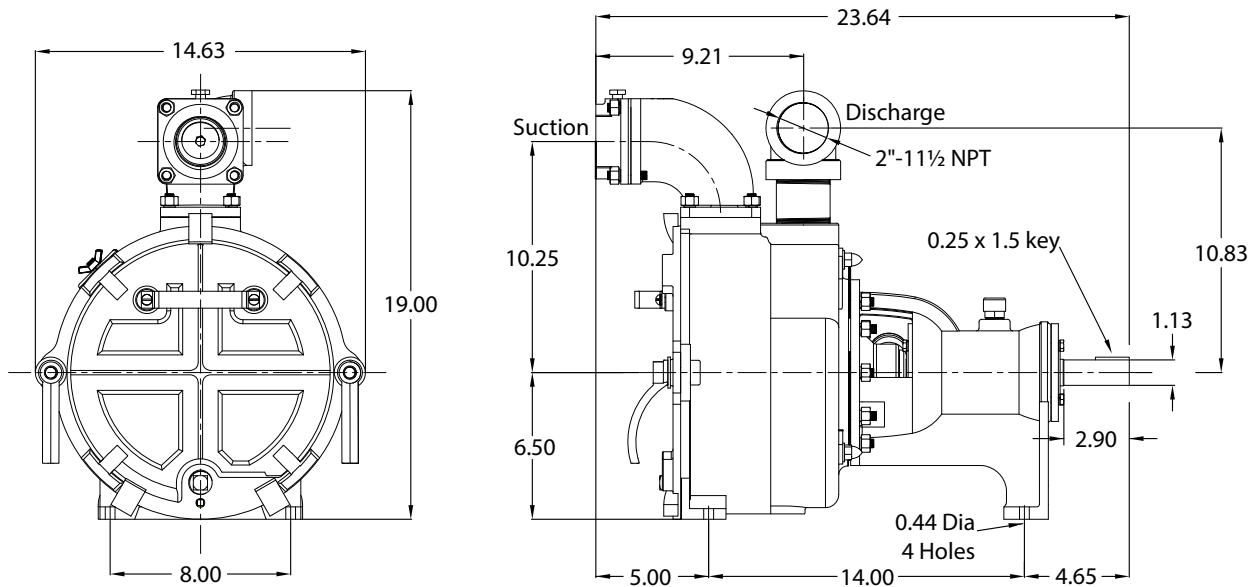

► BSPO3LA8D

DISCHARGE:	3" x 3" ANSI, 125 lbs., flange.
SPHERICAL SLD HNDLG:	1½"
LIQUID TEMPERATURE:	160 °F (71 °C)
CASING:	Cast iron ASTM A-48 class 30.
IMPELLER:	2 vane, open. Cast iron ASTM A-48 class 30.
SHAFT:	High carbon steel.
END COVER PLATE:	Cast iron ASTM A-48 class 30, removable, full diameter.
VOLUTE / WEAR PLATE:	Cast iron ASTM A-48 class 30, replaceable with external clearance adjustment.
SEAL PLATE:	Alloy steel no. 4140, replaceable.
PEDESTAL:	Cast iron ASTM A-48 class 30
BEARING - PUMP END:	Single ball, radial and thrust load, oil lubricated.
BEARING - DRIVE END:	Single ball, radial and thrust load, oil lubricated.
PEDESTAL AND	
BEARING LUBRICATION:	SAE no. 30 non detergent oil, pedestal includes oil level sight gauges.
SEAL:	Single, mechanical, grease lubricated by self-feeding lubricator. Material: carbon / ceramic / Buna-N.
CHECK VALVE:	Elbow and weights are cast iron ASTM A-48 class 30, neoprene flap valve.
SQUARE RINGS:	Buna-N.
HARDWARE:	Corrosion resistant steel.
PAINT:	Air dry enamel, water based.
OPTIONAL EQUIPMENT:	Flexible coupled assy, with base OSHA guard and electric motor.

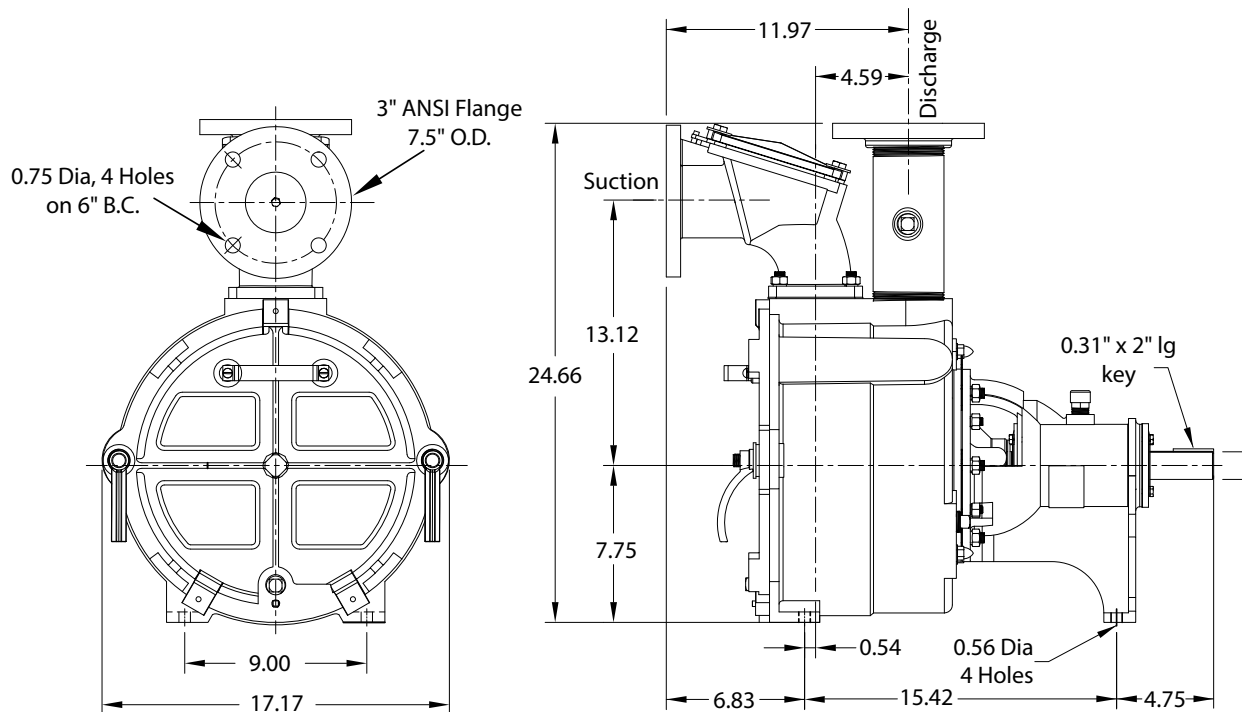

► Receiving inspection

Upon receiving the pump, it should be inspected for damage or shortages. If damage has occurred, file a claim immediately with the company that delivered the pump. If the manual is removed from the packaging, do not lose or misplace.

► Storage

Any product that is stored for a period longer than six (6) months from the date of purchase should be bench tested prior to installation. A bench test consists of, checking the impeller to assure it is free turning and a run test to assure the motor (and switch if provided) operate properly.

► Installation

These instructions cover general installations requirements of the pump. The pump is designed to handle mild industrial corrosives, mud or slurries containing large entrained solids.

There are two different applications for these pumps, first is static lift, which is most common, where the pump is position above the level of liquid to be pumped. The second is a flooded suction, where the liquid to the pump is under pressure.

Mounting, line configuration and priming will be different for each application.

The pressure supplied to the pump is critical to the performance and safety, limit incoming pressure to 50% of the maximum permissible operating pressure as shown on the pump performance curve. For PSI multiply TDH in feet by 0.4335.

Clearance

The chart shows the recommended clearance for servicing the pumps.

Pump Size	In Front of Back Cover	Min. Cover removal
3"	18"	11"
4"	18"	11"

Foundation

The pump foundation should be sufficiently substantial to form a level, rigid support for the combined weight of the pump and driver and maintain alignment of the installed unit.

Foundation bolts, of the proper size, should be imbedded in the concrete. A pipe sleeve, about 2½" diameters larger than the bolt, should be used to allow for final positioning of the bolts. See Figure 1.

Mounting

Mount pump and driver on a common base plate with coupling, must be aligned. Preliminary alignment is necessary after the complete unit has been leveled on the foundation, and again, after the unit is piped, and rechecked periodically as outlined in the following paragraphs. Position unit on foundation and level the base plate, using rectangular metal blocks and shims, or wedges having a small taper as shown in Figure 1.

A gap of ¾" to 1½" should be allowed between the base plate and foundation for grouting. Adjust the metal supports or wedges until the shafts of the pump and driver are level.

Grouting

Grouting compensates for unevenness in the foundation and prevents vibration and shifting after mounting is complete. Build a form around the base plate to contain the grout, and sprinkle area with water to obtain a good bond. The base should be completely filled with a good quality, non-shrinking grout. The usual mixture for grouting is one part Portland cement and two parts sand with sufficient water to flow freely. It is also desirable to grout the leveling pieces, shims or wedges in place. Foundation bolts should be fully tightened when grout has hardened, usually about 48 hours after pouring.

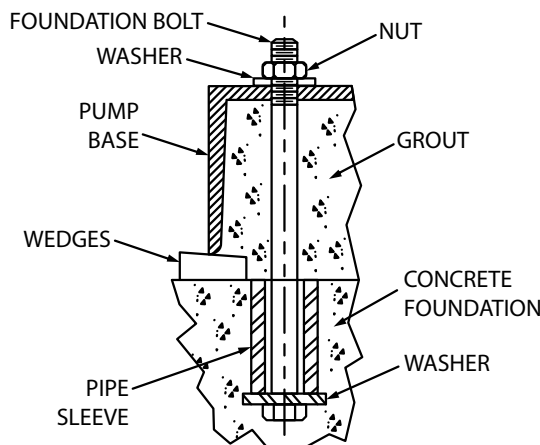

Figure 1

Usually, it is advisable to increase the size of both the suction and discharge pipes at the pump nozzles to have minimum acceptable friction loss, suction pipe should never be smaller in diameter than the pump suction nozzle. When suction pipe is of larger diameter than the pump suction nozzle, an eccentric reducer is required to eliminate possible air or vapor pockets at the pump suction inlet.

Piping

The pump suction and discharge connections are not intended to indicate the required suction and discharge pipe sizes. The pipe diameter must be selected according to the requirements of the pumping system and recommended friction losses for the liquid being pumped.

Both suction and discharge pipes must be supported independently near the pump, so that when piping is connected to the pump, no strain will be transmitted to the pump. Piping should be arranged with as few bends as possible, and, preferably, with long radius elbow whenever possible.

▶ **Material**

Either pipe or hose may be used, however, the material must be compatible with the liquid being pumped. If hose is used in suction lines, it must be rigid-wall, reinforced type to prevent collapse under suction. Using piping couplings in suction lines is **NOT** recommended.

Suction Piping

A horizontal suction line must have a gradual rise to the pump. Any high point in the suction pipe can become filled with air and prevent proper operation of the pump and may cause loss of prime. The pipe and fittings must be free of all air leaks.

Maximum performance is obtained when suction line and pump size are matched. The velocities of 8 to 11 feet per second are obtained when the suction line is sized to the pump suction. This tends to keep solids in suspension and suction line cleaner.

The use of oversized suction line will increase priming time and could cause clogging at the reducers.

▶ **Suction Line in Sump**

If a single suction line is installed in a sump, it should be positioned away from the wall of the sump at a distance equal to 1.5 times the diameter of the suction line.

If there is a liquid flow from an open pipe into the sump, the flow should be kept away from the suction inlet because the inflow will carry air down into the sump, and air entering the suction line will reduce pump efficiency.

If it is necessary to position inflow close to the suction inlet, install a baffle between the inflow and the suction inlet at a distance 1.5 times the diameter of the suction pipe. The baffle will allow entrained air to escape from the liquid before it is drawn into the suction inlet.

If two suction lines are installed in a single sump, the flow paths may interact, reducing the efficiency of one or both pumps. To avoid this, position the suction inlets so they are separated by a distance equal to at least 3 times the diameter of the suction pipe.

Gauges

Pumps are usually drilled and tapped for discharge pressure and vacuum suction gauges. If gauges are required and pumps are not tapped, drill and tap the discharge and suction lines not less than 18 inches from the discharge and suction ports and install in the lines. Do not mount any closer as this may cause inaccurate readings.

▶ **Strainer**

If a strainer is used, make sure the total area of the openings in the strainer is at least three to four times the cross section of the suction line, the openings should not permit passage of solids larger than the solids handling capability of the pump.

BSPO2LA6C	1¼" Solids
BSPO3LA8D	1½" Solids

▶ **Discharge Piping**

On the 3" model a 3/4" air bleed line should be used in order to reduce the priming time to a minimum. This is mandatory on force main installations.

An air-bleed valve (by others) may be placed in this line, but not necessary. A clear plastic line is excellent, allowing the operator to detect any clogging.

There are two ways of returning the airbleed line to the pit.

1. A line discharging above the liquid level. This condition is most accepted, but has the disadvantage of losing its prime if the suction check valve is held open by debris. This is generally not a problem if pump is ran at 1600 RPM or higher.

2. A line discharging below the liquid level. This condition works best at slower speeds where considerable debris is encountered. However, the pipe should not project more than one foot below the low liquid level. The pump will not lose prime, if there are no leaks in the systems.

CAUTION The air-bleed line that is returned to the pit **MUST** be secured against being drawn into the pump suction inlet.

The air bleed return line to the pit must be separated from the suction pipe as far as possible in order to eliminate churning air into the sump liquid.

DANGER DO NOT leave manual shut off valve (if installed in air bleed line), closed during operation. A closed valve may cause a pump which has lost prime to continue to operate without reaching prime, causing dangerous overheating and possible explosive rupture of the pump casing.

Standard designs require the installation of a check valve and a gate valve. The check valve should be installed in the horizontal position to avoid deposits between the disc and the body and should have a spring loaded are or an externally weighted arm. The gate valve is used when cleaning or repairing the check valve and should be down stream from the check valve.

Alignment

For a trouble free operation, the alignment of the pump and power source is critical. The driver and pump shafts, of either a flex coupled or v-belt driven system, must be aligned with and parallel to each other. Check pump and piping after installed and before operation.

Flex-Coupled

Check the coupling faces, as well as the suction and discharge flanges of the pump for horizontal or vertical position by means of a level. Correct the positions, if necessary, by adjusting the supports or wedges under the base plate, as required.

NOTE: A flexible coupling should not be used to compensate for misalignment of the pump and driver shafts. The purpose of the flexible coupling is to compensate for temperature changes and to permit end movement of the shafts without interference with each other, while transmitting power from the driver to the pump.

CAUTION Remove and lock out power to driver.

Field alignment

The faces of the coupling halves should be spaced far enough apart so that they cannot strike each other when the driver rotor is moved toward the pump. The necessary tools for checking the alignment of a flexible coupling are a straight edge and a taper gauge or a set of feeler gauges.

NOTE: In most cases where extreme accuracy is necessary, a dial indicator or laser alignment tool may be required to align coupling.

Angular alignment check is made by inserting a taper gauge or feelers between the coupling faces at 90 degree intervals around the coupling.

The unit will be in angular alignment when the coupling faces are exactly the same distance apart at all points. (See Figure 2).

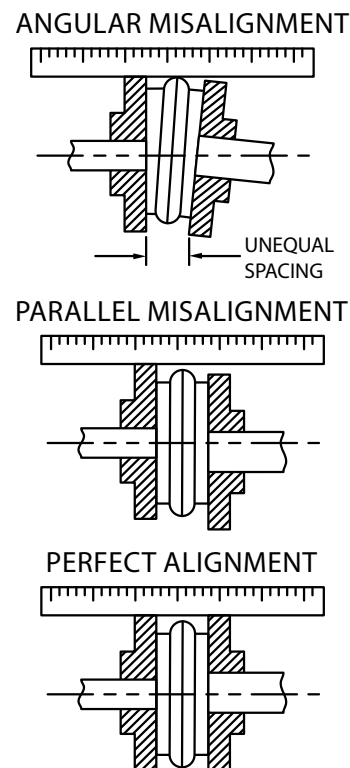

Figure 2

Parallel alignment check is made by placing a straight edge across both coupling rims at the top, bottom and at both sides. The unit will be in parallel alignment when the straight edge rests evenly on the coupling rim at all positions. Allowance may be necessary for temperature changes and for coupling halves that are not of the same outside diameter. Care must be taken to have the straight edge parallel to the axis of the shafts. Correction for Angular and Parallel Misalignment is made by adjusting the shims under the driver. After each change, it is necessary to recheck the alignment of the coupling halves, as adjustment in one direction may disturb adjustments already made in another direction.

The permissible amount of coupling misalignment will vary with the type of pump and driver, but should be limited to approximately 0.002" per inch of shaft diameter when final adjustment is made.

When the units are lined up cold, it is necessary to make allowance for the vertical rise of the driver caused by heating when in operation. When the preliminary alignment has been completed the foundation, bolts should be tightened evenly, but not too firmly.

⚠ DANGER *Coupling or belt guards must be used to avoid serious injury to operating personnel.*

▶ **V-Belt Driven**

Be sure the pulleys are properly aligned and the power source and pump are parallel (see Figure 2b). If the drive system uses multiple belt, make sure they are of a matched set.

Belts must be adjusted in accordance with the belt manufactures instructions. If belts are too loose, slippage will occur. If belts are too tight, there will be excessive power loss and possible bearing failure. Belts and pulleys should be properly selected for the desired conditions.

▶ **Belt Tensioning**

New belt drives should be checked after 5, 20 and 50 hours of operation and re-tension as required. Then check and re-tension monthly or at least in 500 hour intervals.

The ideal belt tension is the lowest tension at which the belt will not slip under peak load. **DO NOT** over-tension belts, as this will shorten belt life as well as bearing life.

Under-tensioning will cause belt slippage. Belt slippage can be caused by dirt, grease, oil and other foreign materials.

▶ **Wiring**

For electric motor drives, connect power supply to conform with national and local codes. Line voltage and wire capacity must match the ratings stamped on the motor nameplate.

▶ **Rotation**

Before starting the pump, check the required direction of rotation of the pump. The proper direction is indicated by a direction arrow on the pump casing. Separate the coupling halves, then start motor to see that it rotates in the direction required by the pump.

If it does not, reverse any two main leads of the 3-phase wiring to the motor. The coupling halves can be reconnected and the pump primed for starting.

Pre-Operation

The following important items should be checked as pump is started and placed in operation.

- a) Pump and driver securely bolted.
- b) Coupling properly aligned.
- c) Piping completed.
- d) Correct pump rotation.
- e) Pump shaft turns freely.
- f) Discharge valve closed.
- g) Suction valve open (if used).

- h) Coupling Guard installed
- i) Pump fully primed
- j) Pump and driver properly lubricated.

Only after these items have been checked should the pump be started.

▶ **Lubrication**

Check the eyeglass (13) on side of pedestal (12) for proper amount of SAE 30 non-detergent oil.

Check that grease cup (32) is full of grease and activated. (See page 09)

▶ **Priming**

Before starting the pump, the casing and suction line must be filled with liquid, by removeing fill cover plates (75) on 2" models or hatch cover (66) on 3" models. The pump must not be run until it is completely filled with liquid, because of danger of injuring some of the parts of the pump which depend upon liquid for lubrication. The discharge gate vane should be closed during priming. Be sure the mechanical seal and power frame are supplied with the proper lubrication.

⚠ CAUTION *Never operate pump unless there is liquid in the pump casing. The pump will not prime when dry. Extended operation of a dry pump will destroy the seal.*

▶ **Priming by Suction Pressure**

When operating with suction pressure (flooded suction), remove the fill cover plates (75) at the top of the casing or remove hatch cover (66) and when pump is filled with liquid, replace.

▶ **Priming with foot valve and strainer**

A foot valve and strainer may be installed on the lower end of the suction pipe to keep pump filled with liquid.

SHAFTS NOT PARALLEL

SHAFTS NOT IN LINE

SHAFTS PARALLEL AND SHEAVES IN LINE

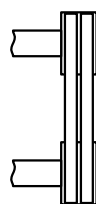
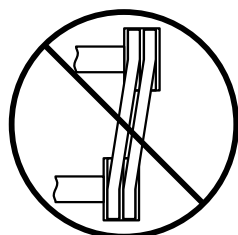
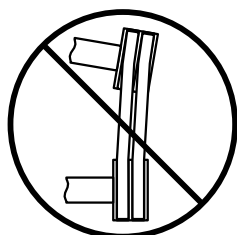

Figure 2b

Incorporate filler pipe in discharge pipe between pump and check valve. Remove fill plates (75) or hatch (66), then fill suction pipe and pump with liquid. When pump is full of liquid, replace fill plates or hatch and close filler pipe.

CAUTION When a foot valve and strainer are installed on the suction pipe, a spring loaded type check valve **MUST** be installed next to the pump in the discharge piping to prevent pump rupture from water hammer shock.

Priming by means of primer pump or ejector, attached to the pump, will also remove air from suction pipe and pump casing. When pump is filled with liquid, start motor and slowly open discharge gate valve.

▶ Starting the Pump

Consult the operating manual for the power source before starting the power source.

On initial start up, the gate valve in the discharge piping should be closed and slowly opened after pump is up to speed and pressure developed.

WARNING **DO NOT operate pump for any appreciable length of time against a closed discharge valve, as this may heat trapped liquid excessively and damage the pump or seal.**

▶ Overheating

The operating temperature of these pump is 160 °F max. Do not operate above this temperature. Closed valves in the suction and discharge line can cause the overheating.



DANGER **Operating against closed valves could bring the liquid to a boil, build pressure, and cause the pump to rupture or explode.**

The pump is equipped with a pressure relief valve to safeguard against rupture or explosion due to heat. The valve will open if casing vapor pressure reaches a critical point.



DANGER **Stop the pump if overheating occurs, and allow to cool before servicing. DO NOT remove any covers, plates, gauges, fittings or pressure relief valve from the pump. Liquid within the pump can reach boiling temperatures and pressure in the pump can cause ejection of parts and liquid. AFTER the pump cools the pump can be drained and serviced.**

▶ Bearing Temperature

Normally bearings run at higher than ambient temperatures because of heat generated by friction. Normal bearing temperatures up to 160 °F and can operate up to 180 °F safely.

Check bearing temperatures with a contact-type thermometer against the housing. Record this temperature for future use. A sudden bearing temperature increase is a warning that the bearings are at the point of failing to operate properly. Check lubricant for proper viscosity at correct level. Shaft misalignment can cause overheating.

▶ Strainer Check

If a strainer is installed, be sure to check and clean regularly or when the pump flow rate begins to drop. If a vacuum suction gauge has been installed, monitor and record the readings to detect strainer blockage.

Never introduce air or steam pressure into the pump casing or piping to remove a blockage. This could result in personal injury or equipment damage. If back flushing is necessary, liquid pressure must be limited to 50% of the maximum permissible operating pressure shown on the performance curve.

▶ Pump Vacuum Check

With pump inoperative, install a vacuum gauge in the system. Block the suction line and start the pump. At operating speed the pump should pull a vacuum of 20 inches or more of mercury.

Open the suction line and read the vacuum gauge with the pump primed and operation speed. Shut off pump, the vacuum gauge reading will immediately drop proportionate to static suction lift, and should then stabilize. If reading falls rapidly after stabilization, an air leak exists. Check the vacuum gauge installation before checking for the source of the leak.

▶ Stopping the Pump

Never stop the flow suddenly. If the pumped liquid is stopped abruptly, damaging shock waves can be transmitted to the pump and piping system. Close all connecting valves slowly.

Reduce the throttle speed slowly on engine driven pumps and allow the engine to briefly idle before stopping.

If the application involves a high discharge head, gradually close the discharge-throttling valve before stopping the pump. Lock out and disconnect the power source after stopping the pump.



Do not operate the pump against a closed discharge throttling valve for long periods of time. Components could deteriorate, liquid could come to a boil and build pressure, causing pump casing to rupture or explode.

► Cold Weather Preservation

Remove pipe plugs (39), drain the pump to prevent freezing and flush out any solids with a hose. Operate the pump for approximately one minute to remove any remaining liquid.

► Preventive Maintenance

The following is a general recommendation for preventive maintenance. Regardless of the application, following a routine preventive maintenance program will help assure trouble-free performance and long life from your pump.

A first inspection of parts for NEW applications should be approx. 250 hours. This will give you some insight of the wear rate for your application.

On a Daily Basis:

- Check the general conditions, such as temperature, vibrations, unusual noises, cracks, leaks, loose hardware, etc.
- Check pump performance and record gauge readings (if equipped), speed and flow. Changes in gauge readings can indicate problems that can be corrected before damage or failure occurs.

On a Weekly Basis:

- Check bearing and mechanical seal lubrication. Check that grease cup is full.

On a Monthly Basis:

- Check V-Belts (if equipped).

Every Six Months:

- Check front impeller/wear and rear impeller/seal plate clearance.

Once a Year:

- Inspect and clean the check valve assembly. Check the valve flapper (60) is not broken or damaged by use. Deposits may also build up between the rubber and the seat.
- Check pump and driver alignment.
- Check to see if there is any shaft deflection.
- Check bearings and bearing housing.
- Replace bearing lubrication.

If the impeller (33) is removed for any reason and the mechanical seal is in good condition, **DO NOT** disturb the seal as this will cause the seal to leak and require replacing.

If the mechanical seal (26) ever needs replacing, check the following parts for wear or deterioration; volute (42), seal plate (41), impeller (33), shaft (9), o-rings (27), (31), (43) & (44).

► Lubrication

Bearings - On the side of the pedestal (12), check the oil level through the sight glass (13). The level should be up to the center of the sight glass. In order for both bearings to be lubricated properly, the pump must be level. If the oil is low, remove vent plug (11) and add SAE 30, non-detergent oil. Inspect and clean if required vent plug before replacing it on pedestal. It is recommended that this oil be changed at least once a year.

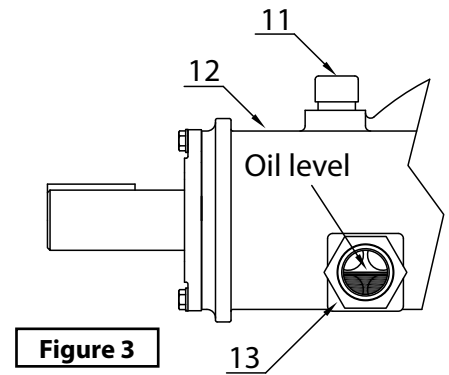

Figure 3

Mechanical Seal (see Figure 4) - A self-feeding lubricating grease cup (32) is provided to supply grease to the shaft seal (26).

The grease cup is empty when the wing nut, positioned at the outer end of the threaded plunger shaft, recedes to the cap of the grease cup.

To refill the grease cup, rotate the wing nut clockwise as far as it will go. Attach a grease gun to the zerk fitting, then fill until grease oozes from the relief hole on the side of cup. For operation, return the wing nut to the end of the plunger.

CAUTION *Never force the plunger into the grease cup as this can cause seal failures.*

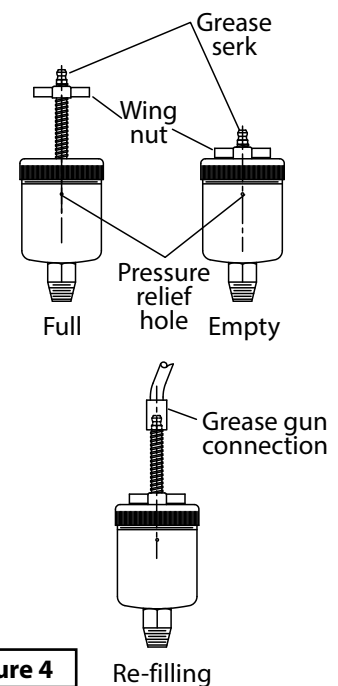

Figure 4

⚠ CAUTION *Never remove the grease cup and insert a zerk fitting for lubricating this seal or the seal will be permanently damaged.*

The use of a #1 grease is normally recommended. When high ambient temperatures are encountered, such as direct sunlight, a #2 grease can be used.

Use a water resistant, non-fibrous grease. Lithium based greases are excellent and moly disulfide grease is acceptable. The sodium soap base greases are the only non-water resistant types that are **NOT** acceptable.

If the pump is inoperative for a long period of time, or appears not to use any grease, remove and clean the grease cup (32) thoroughly. Caked grease in the cup can create a problem of not lubricating the seal. Under normal conditions, the grease cup full of grease will last three to four months.

If a grease seal requires grease every day, and is not leaking past the outer lip seal, it indicates that the seal is wearing out. The internal pressure of the pump will often force the cup plunger out when the seal leaks badly.

► **Shaft Seal Replacement**

Through Hatch Cover - Remove handle nuts (49), washers (48) and pry off hatch cover (45). Next remove cap nuts (36), washers (37) and pull the volute (42) and seal plate (41) out of pump case (40).

Remove impeller nut (35), (standard right hand thread) and washer (34). Remove impeller (33) with the use of a wheel puller. Next, remove the seal's (26) spring holder and spring.

The rotating assembly and stationary seat can now be removed without further disassembly, but it is easier to remove hex nuts (21), washers (23), grease cup (25), to remove casing cover (25) before removing these parts. By using this method, the lip seal (22) can be inspected and replaced if necessary, and seat area cleaned. Examine and replace if necessary, shaft slinger (20) and o-ring (27).

⚠ CAUTION *Lapped and polished faces of new seal are easily scratched and damaged. Protect from damage, dirt and fingerprints.*

Clean shaft (9) and counterbore in casing cover (25) with 180 to 240 grit emery cloth. Shoulder on shaft must **NOT** be sharp, polish and round to 1/32" radius. Lubricate shaft (9), seat counterbore in casing cover (25) and rubber members of seal with a compatible lubricant (*U.S. Seal Mfg. P-80 or equal*) or SAE 10 non-detergent oil can be used on the rubber parts.

Check seal surfaces to be sure they are free of any dirt, grit or lubricants. Install the stationary seat into casing cover (25). Next install the rotating portion, with dry clean hands grasp the rotating portion and with a circular, rocking motion, push onto shaft (9) sliding it down against the stationary seat.

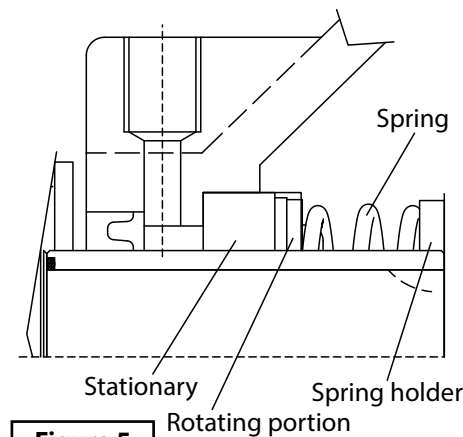

Figure 5

Once rotating portion is in place, install the spring and the spring holder. Replace impeller (33), washer (34) and nut (35) onto shaft (9) and torque per chart.

Impeller Nut Torque Values	
Model	Torque
BSPO2LA6C	55 ft. lbs.
BSPO3LA8D	100 ft. lbs.

Place seal plate (41) over the studs of the volute (42) and insert this assembly over the impeller with the volute studs projecting through the case (40).

Replace the washers (37) and cap nuts (36) onto studs (38), finger tight only, at this time.

Replace o-ring (43) on the volute and o-rings (31) and (44) on BSPO2LA or two o-rings (44) on BSPO3LA on the hatch cover, grease these o-rings thoroughly.

Now install case cover (45) into case (40), place flat washers (48) onto studs (47) and tighten down with handle nuts (49). These handle nuts can be sufficiently tightened by hand. This method of securing the casing cover first, centers the volute properly over the impeller. Now the cap nuts (36) can be tightened.

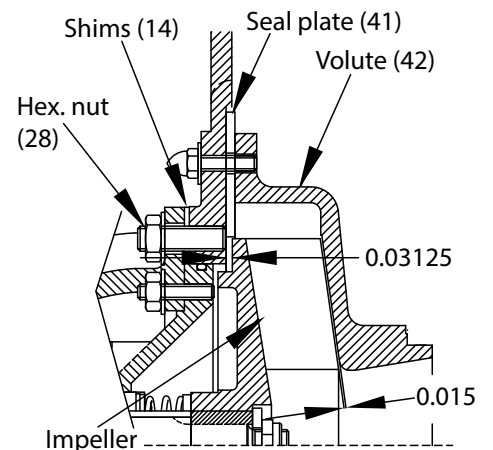

Figure 6

The factory clearance between the impeller (33) and the wear surface of the volute (42) is 0.015 inches. This clearance is adjustable by adding or removing of the horseshoe shims (14) located between bearing housing (12) and casing (40). Add or remove shims (14) in equal amounts at each location, until the impeller rubs slightly, then add one thin shim (0.015" thick) at each location and tighten nuts (28) securely.

NOTE: As wear clearance increases between the impeller and volute, the pump head pressure is reduced and priming ability is affected.

A new pump will have a clearance of 0.03125" between the impeller (33) and seal plate (41). When this wears to 0.125" or more, priming is affected and especially on high suction lifts.

► **Shaft Seal Replacement By Removing Pedestal - for BSPO2LA Only** - First remove the belt or coupling guard and relieve the belt tension on belt-drive units and remove belts or remove bolts from motor base on the flex coupling units and detach coupling and remove motor and coupling. Next remove the pedestal bolts that attach the pedestal to the base.

IMPORTANT: The BSPO3LA8D impeller is too large to be removed by this procedure.

Remove hex nuts (28), washers (29) and nuts (21), washers (23) and remove pedestal assembly. Next remove impeller nut (35) and washer (34) from shaft. Impeller nut is standard right hand thread. Now remove impeller (33), use wheel puller if necessary.

Remove the grease cup (32) from casing cover (25). Next remove the hex nuts (21) and washers (23).

With two pry bars force the casing cover along with old seal off the shaft. Lip seal (22) in casing cover (25), can be inspected and replaced if necessary, and seat area cleaned. Examine and replace if necessary, shaft slinger (20) and o-ring (27).

CAUTION *Lapped and polished faces of new seal are easily scratched and damaged. Protect from damage, dirt and fingerprints.*

Clean shaft (9) and counterbore in casing cover (25) with 180 to 240 grit emery cloth. Shoulder on shaft must **NOT** be sharp, polish and round to 1/32" radius.

Lubricate shaft (9), seat counterbore in casing cover (25) and rubber members of seal with a compatible lubricant (U.S. Seal Mfg. P-80 or equal) or SAE 10 non-detergent oil can be used on the rubber parts. Check seal surfaces to be sure they are free of any dirt, grit or lubricants. Install the stationary seat into casing cover (25).

Next install the rotating portion, with dry clean hands grasp the rotating portion and with a circular, rocking motion, push onto shaft (9) sliding it down against the stationary seat.

Once rotating portion is in place, install the spring and the spring holder. Replace impeller (33), washer (34) and nut (35) onto shaft (9) and torque per chart.

Impeller Nut Torque Values	
Model	Torque
BSPO2LA6C	55 ft. lbs.

Place pedestal assembly into pump and set clearance by adding or removing shims (14) until the impeller rubs slightly, then add one thin shim (0.015 thick) at each location and tighten hex nuts.

NOTE: As wear clearance increases between the impeller and volute, the pump head pressure is reduced and priming ability is affected.

A new pump will have a clearance of 0.03125" between the impeller (33) and seal plate (41). When this wears to 0.125" or more, priming is affected and especially on high suction lifts.

Re-assemble the pedestal to the base and assemble the coupling and motor or sheaves, belts and guard to the unit. Adjust belts or coupling as specified.



► BSPO2LA6C

Figure 7

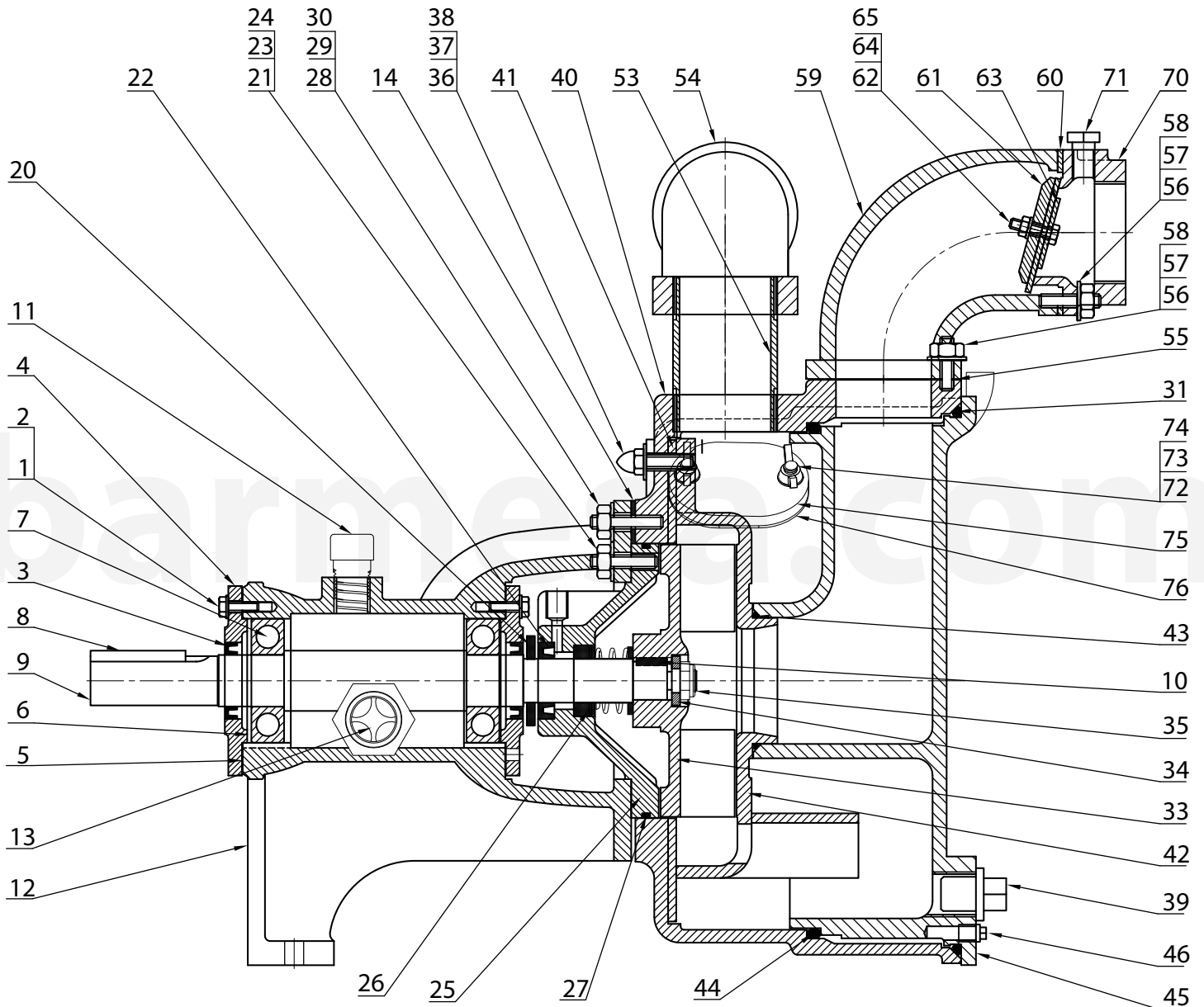

For repair parts, please supply: model number and serial as shown on nameplate, and part item number and description as shown on Parts List.

► BSPO2LA6C

Figure 8

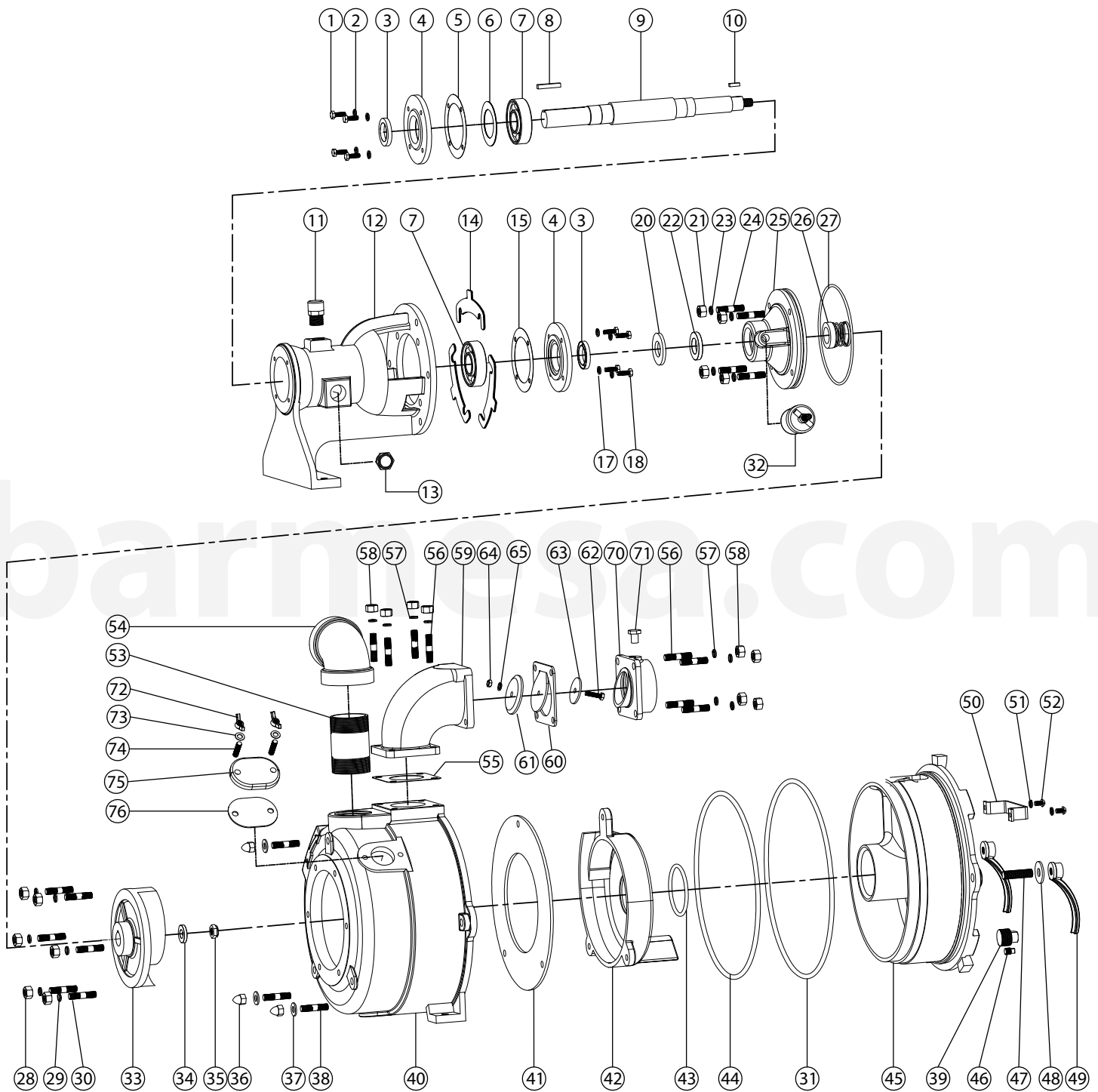

For repair parts, please supply: model number and serial as shown on nameplate, and part item number and description as shown on Parts List.

► BSPO2LA6C

ITEM	QTY	DESCRIPTION
1	4	Cap Screw - 1/4-20 x 0.75" lg
2	4	Lockwasher - 1/4"
3	2	Lip Seal
4	2	Bearing Cap
5	1	Gasket
6	2	Adjustment Pad
7	2	Ball Bearing
8	1	Key - 1/4" Sq x 1.50" lg
9	1	Shaft
10	1	Impeller Key - 3/16" Sq x 0.69" lg
11	1	Vent Plug
12	1	Bearing Housing
13	1	Sight Glass
14A	6	Shim, 0.030" thk
14B	6	Shim, 0.015" thk
15	1	Gasket
17	4	Lockwasher - 1/4"
18	4	Cap Screw - 1/4-20 x 0.75" lg
20	1	Slinger
21	4	Hex Nut - 3/8-16
22	1	Lip Seal
23	4	Lock washer - 3/8
24	4	Stud - 3/8-16 x 1.50" lg
25	1	Casing Cover
26	1	Mechanical Seal - 1"
27	1	O-ring - Buna-N
28	6	Hex Nut - 3/8-16
29	6	Lockwasher - 3/8"
30	6	Stud - 3/8-16 x 1.50" lg
31	1	O-ring
32	1	Grease Cup
33	1	Impeller - 6.20" Dia
34	1	Impeller washer
35	1	Impeller Nut - 1/2-20, stainless/Nylock
36	3	Cap Hex Nut - 3/8-16 Nylock
37	3	Flat washer - 3/8"

ITEM	QTY	DESCRIPTION
38	3	Stud - 3/8-16 x 1.75" lg
39	3	Pipe Plug - 3/4" NPT
40	1	Pump Casing
41	1	Seal Plate
42	1	Volute
43	1	O-ring
44	1	O-ring
45	1	Case Cover
46	1	Pipe Plug - 1/8" NPT
47	2	Stud - 1/2-13 x 2.00" lg Stainless
48	2	Flat Washer - 1/2"
49	2	Handle Nut
50	1	Cover Handle
51	2	Lockwasher - 1/4"
52	2	Round Head Screw - 1/4-20 x 1/2" lg
53	1	Pipe Nipple - 2" NPT x 3.50" lg
54	1	Elbow - 2" NPT
55	1	Gasket
56	8	Stud - 3/8-16 x 1.50" lg
57	8	Lockwasher - 3/8"
58	8	Hex Nut - 3/8-16
59	1	Suction Elbow
60	1	Valve Flapper/Gasket
61	1	Check Valve Weight
62	1	Capscrew - 1/4-20 x 1.00" lg
63	1	Valve Weight
64	1	Hex Nut - 1/4-20, Stainless
65	1	Lockwasher - 1/4"
70	1	Suction Flange - 2"
71	1	Pipe Plug - 1/4" NPT
72	2	Wing Nut - 5/16-18
73	2	Flatwasher - 5/16"
74	2	Stud - 5/16-18 x 1.50" lg
75	1	Fill Cover Plate
76	1	Gasket, Fill Cover Plate

For repair parts, please supply: model number and serial as shown on nameplate, and part item number and description as shown on Parts List.

► BSPO3LA8D

Figure 9

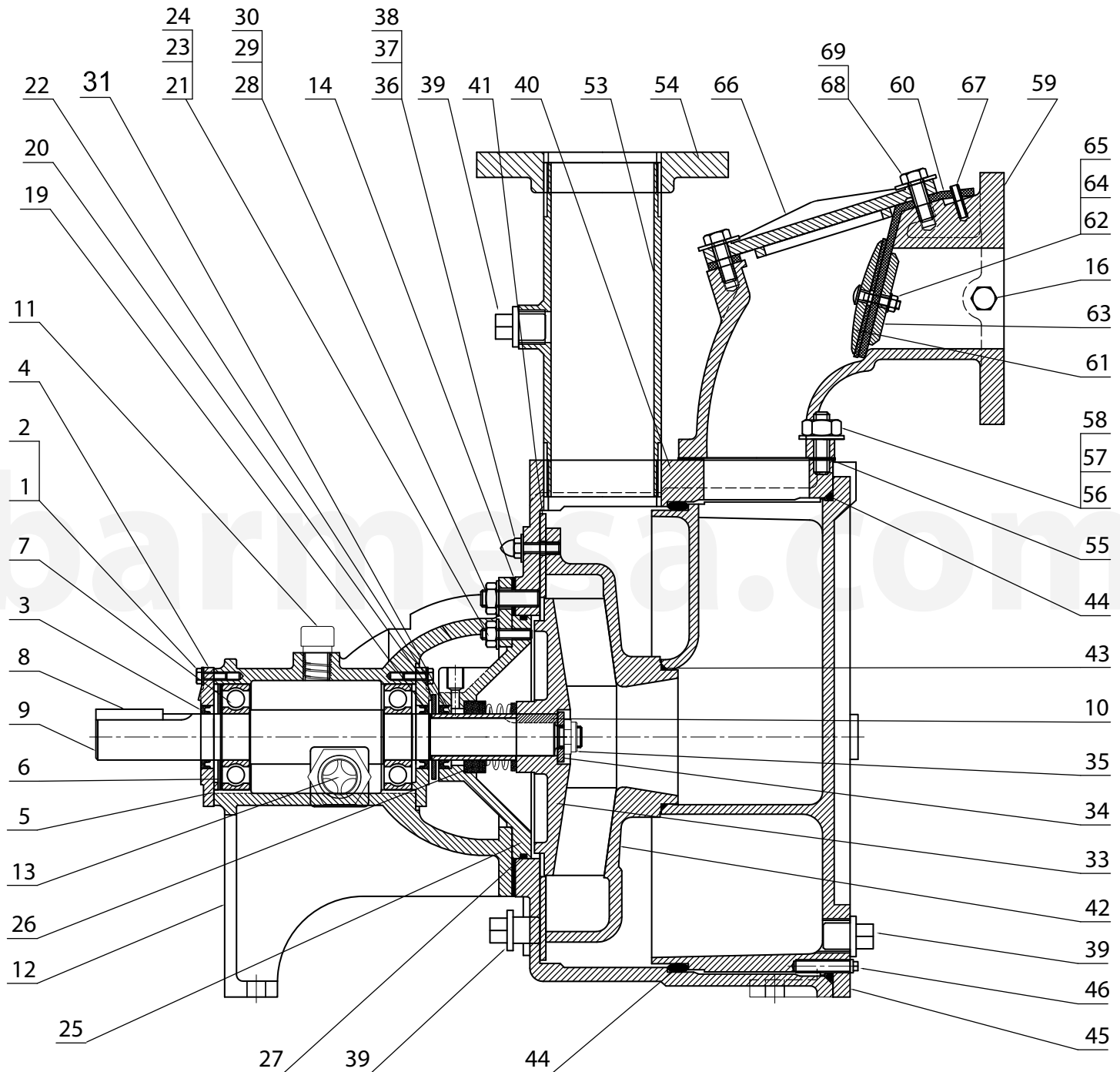

For repair parts, please supply: model number and serial as shown on nameplate, and part item number and description as shown on Parts List.

► BSPO3LA8D

Figure 10

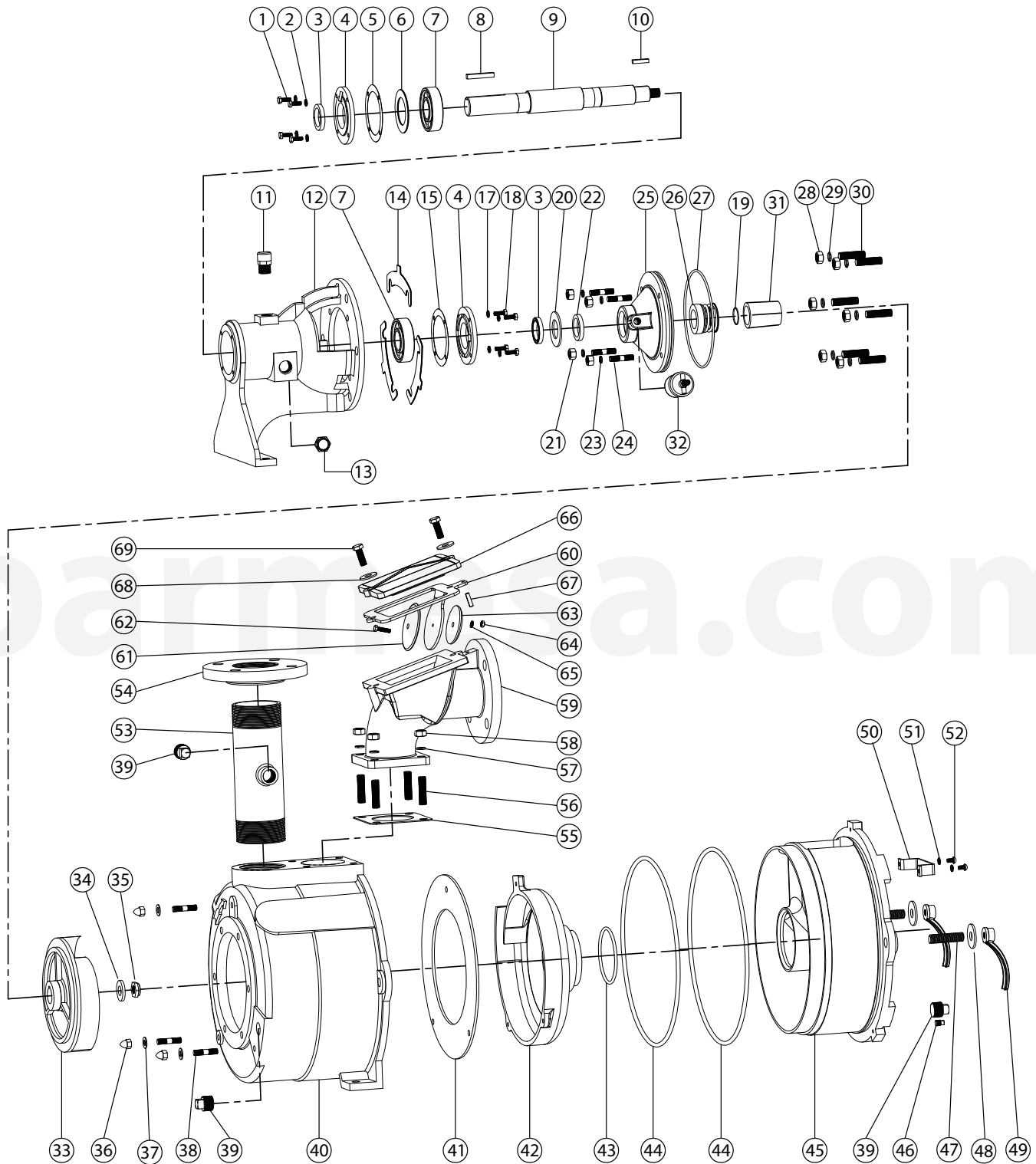

For repair parts, please supply: model number and serial as shown on nameplate, and part item number and description as shown on Parts List.

► BSPO3LA8D

ITEM	QTY	DESCRIPTION
1	4	Cap Screw - 1/4-20 x 0.75" lg
2	4	Lockwasher - 1/4"
3	2	Lip Seal, 1.875 x 1.375 x 0.25
4	2	Bearing Cap
5	1	Gasket
6	2	Adjustment Pad
7	2	Ball Bearing, 6307
8	1	Key - 5/16" Sq x 2.00" lg
9	1	Shaft
10	1	Impeller Key - 1/4" Sq x 1.00" lg
11	1	Vent Plug, 1/2-14 NPT
12	1	Bearing Housing
13	1	Sight Glass, 3/4-14 NPT
14A	6	Shim, 0.035" thk
14B	6	Shim, 0.015" thk
15	1	Gasket
16	1	Pipe Plug 1/8" NPT
17	4	Lockwasher - 1/4"
18	4	Cap Screw - 1/4-20 x 0.75" lg
19	1	O-ring, Buna-N, 028 x 1.8
20	1	Slinger
21	4	Hex Nut - 3/8-16
22	1	Lip Seal, 01.875 x 1.375 x 0.25
23	4	Lock washer - 3/8
24	4	Stud - 3/8-16 x 1.50" lg
25	1	Casing Cover
26	1	Mechanical Seal, DY20-1.375
27	1	O-ring - Buna-N, 0177 x 3.55
28	6	Hex Nut - 1/2-13
29	6	Lockwasher - 1/2"
30	6	Stud - 1/2-13 x 1.75" lg
31	1	Shaft Sleeve, Stainless
32	1	Grease Cup - 3 oz
33	1	Impeller
34	1	Impeller washer
35	1	Impeller Nut - 5/8-16, stainless/Nylock
36	3	Cap Hex Nut - 3/8-16 Nylock
37	3	Flat washer - 3/8"

ITEM	QTY	DESCRIPTION
38	3	Stud - 3/8-16 x 1.75" lg
39	3	Pipe Plug - 3/4" NPT
40	1	Pump Casing
41	1	Seal Plate
42	1	Volute
43	1	O-ring, Buna-N, 0100 x 5
44	2	O-ring, Buna-N, 0340 x 7
45	1	Case Cover
46	1	Pipe Plug - 1/8" NPT
47	2	Stud - 5/8-11 x 2.50" lg Stainless
48	2	Flat Washer - 5/8"
49	2	Handle Nut
50	1	Cover Handle
51	2	Lockwasher - 1/4"
52	2	Round Head Screw - 1/4-20 x 1/2" lg
53	1	Pipe Nipple - 3" NPT
54	1	Flange - 3"
55	1	Gasket
56	4	Stud - 1/2-13 x 2" lg
57	4	Lockwasher - 1/2"
58	4	Hex Nut - 1/2-13
59	1	Suction Elbow - 3"
60	1	Valve Flapper/Gasket
61	1	Check Valve Weight
62	1	Carriage Bolt - 1/4-20 x 1.25" lg
63	1	Valve Weight
64	1	Hex Nut - 1/4-20, Stainless
65	1	Lockwasher - 1/4", Stainless
66	1	Hatch Cover
67	1	Spring Pin - 1/4" Dia x 1" lg
68	2	Flatwasher - 7/16"
69	2	Capscrew - 7/16-14 x 1.25" lg

For repair parts, please supply: model number and serial as shown on nameplate, and part item number and description as shown on Parts List.

► Locating Trouble

To aid in locating problems, it is recommended the following to be installed.

- a) Install a vacuum gauge on the suction side of the pump.
- b) Install a low-pressure gauge on the discharge side of the pump.

Use a small valve for attaching the gauges and keep them shut off when not in use. If left to flutter with pulsations a vacuum gauge will develop a crack in the internal tube causing it to leak unknowingly and give priming problems.

By using the vacuum and pressure gauges, you should be able to locate most problems that will occur. Air leaks on the suction side are the most common problems encountered in self-priming pumps.

It may be necessary to connect a pressure water supply to the drain hole of the pump and hydrostatically test it if all checks fail to identify the location of the leak. Keeping the water pressure low, 5 to 10 lb is ideal. Higher pressures may not show an o-ring leak.

Also remove the cover from the grease cup to permit water to escape should the shaft seal be leaking. If the above shows no leaks, remove bolts from the the suction flange and insert a solid steel backing plate and tighten the flange.

If with the pump running, the vacuum gauge reads as much or more than during normal operation, then the problem is most likely in the suction pipe or sump area. Don't overlook the possibility of air entering the suction line, air that could be coming from the air bubbler control pipe (if used).



⚠ DANGER *Allow pump to cool before servicing. DO NOT remove any covers, plates, gauges, or fittings from the pump. Liquid within the pump can reach boiling temperatures and pressure in the pump can cause ejection of parts and liquid. AFTER the pump cools the pump can be drained and serviced.*

⚠ WARNING *Always wear eye protection when working on pumps. Do not wear loose clothing that may become entangled in moving parts.*

ITEM	AREAS TO CHECK	CORRECTION
3	The leaking of these Lip seals can be caused by a plugged breather cap (11) or too high an oil level in the pedestal (12).	Check oil level in pedestal, see page 16. Clean or replace breather cap.
27	The leaking of this o-ring becomes critical on high suction lifts. Moreso if the clearance becomes great due to sever impeller-seal plate wear.	Adjust clearance. See page 10, Figure 6.
31	If the o-ring leakes, a priming problem will exist.	Check the chamfer which the o-ring seats against is clean and smooth. Check o-ring is not torn or nicked. Grease the o-ring and the area it seats when installing.
44	This o-ring must not leak around the top half of the casing or suction problems can exist.	Always grease this o-ring and the area it slides in before inserting case cover (45).



Risk of electric shock. Always disconnect the pump from the power source before handling inspections or repairs.

SYMPTOM	POSSIBLE CAUSE(S)	CORRECTIVE ACTION
Little or no discharge and will not prime.	<ol style="list-style-type: none"> 1. Pump body not filled with water. 2. Total head too high. 3. Suction head higher than pump designed for. 4. Impeller partially or completely plugged. 5. Leak in suction line. 6. Foot-valve too small. 7. Impeller damaged. 8. Foot-valve or suction line not submerged deep enough in water, pulling air. 9. Insufficient inlet pressure or suction head. 10. Suction piping too small. 11. Body gasket leaking. 12. Suction or discharge line valves closed. 13. Piping damaged. 14. Clogged strainer or foot-valve. 	<ol style="list-style-type: none"> 1. Fill pump body with water. 2. Shorten suction head. 3. Lower suction head, install foot-valve and prime. 4. Disassemble pump and clean out impeller. 5. Repair or replace suction line. 6. Match foot-valve size to piping or install one larger size foot-valve. 7. Disassemble pump and replace impeller. 8. Submerge lower in water. 9. Increase inlet pressure by adding more water to tank or increasing back pressure by turning gate valve on discharge line partially closed. 10. Increase pipe size to pump inlet size or larger. 11. Replace. 12. Open. 13. Clean or replace. 14. Clean or replace.
Loss of suction after satisfactory operation.	<ol style="list-style-type: none"> 1. Air leak in suction line. 2. When pump was last turned off, water siphoned out of pump body. 3. Suction head higher than pump designed for. 4. Insufficient inlet pressure or suction head. 5. Clogged foot-valve, strainer or pump. 6. Defective wearplate. 	<ol style="list-style-type: none"> 1. Repair or replace suction line. 2. Refill (reprime) pump body before restarting. 3. Lower suction head, install foot-valve and prime. 4. Increase inlet pressure by adding more water to tank or increasing back pressure by turning gate valve on discharge line to partially closed. 5. Unclog or replace. 6. Replace.
Pump overloads driver.	<ol style="list-style-type: none"> 1. Total head lower than pump rating, unit delivering too much water. 2. Specific gravity and viscosity of liquid being pumped different than the pump rating. 	<ol style="list-style-type: none"> 1. Increase back pressure by turning gate valve on discharge line to partially closed position that will not overload motor. 2. Consult factory.
Pump vibrates and/or makes excessive noise.	<ol style="list-style-type: none"> 1. Mounting plate or foundation not rigid enough. 2. Foreign material in pump causing unbalance. 3. Impeller bent. 4. Cavitation present. 5. Piping not supported to relieve any strain on pump assembly. 	<ol style="list-style-type: none"> 1. Reinforce. 2. Disassemble pump and remove. 3. Replace impeller. 4. Check suction line for proper size and check valve in suction line if completely open, remove any sharp bends before pump and shorten suction line. 5. Make necessary adjustments.
Pump runs but no fluid.	<ol style="list-style-type: none"> 1. Air leak in suction piping. 2. Pump located too far from fluid source. 3. Gate valve closed. 4. Clogged strainer. 5. Fouled foot-valve. 6. Discharge height too great. 7. Fouled impeller. 8. Faulty mechanical seal. 	<ol style="list-style-type: none"> 1. Replace. 2. Replace. 3. Open. 4. Clean or replace. 5. Clean or replace. 6. Lower the height. 7. Clean or replace. 8. Replace.
Pump leaks at shaft.	<ol style="list-style-type: none"> 1. Worn mechanical seal. 2. Seal not installed properly. 	<ol style="list-style-type: none"> 1. Replace. 2. Follow service instructions for installing seal.

NOTE: Barmesa Pumps assumes no responsibility for damage or injury due to disassembly in the field. Disassembly of the pumps or supplied accessories other than at Barmesa Pumps or its authorized service centers, automatically voids warranty.

BARMESA PUMPS FACTORY WARRANTY

Barmesa Pumps warrants that products of our manufacture will be free of defects in material and workmanship under normal use and service for 18 months from date of manufacture or 12 months from installation date whichever occurs first. This warranty gives you specific legal rights, which vary from state to state.

This warranty is a limited warranty, and no warranty related claims of any nature whatsoever shall be made against Barmesa Pumps, until the ultimate consumer or his/her successor notifies us in writing of the defect and delivers the product and/or defective part(s) freight prepaid to our factory or nearest authorized service station as instructed by Barmesa Pumps. THERE SHALL BE NO FURTHER LIABILITY, WHETHER BASED ON WARRANTY, NEGLIGENCE OR OTHERWISE. PRODUCT SHALL BE EITHER REPLACED OR REPAIRED AT THE ELECTION OF BARMESA PUMPS. Guarantees relating to performance specifications provided in addition to the foregoing material and workmanship warranties on a product manufactured by Barmesa Pumps, if any, are subject to possible factory testing. Any additional guarantees, in the nature of certified performance specifications or time frame must be in writing and such writing must be signed by our authorized factory manager at time of order placement and/or at time of quotation. Due to inaccuracies in field testing and should a conflict arises between the results of field testing conducted by or for the user, Barmesa Pumps reserves the right to have the product returned to our factory for additional testing.

This warranty shall not apply when damage is caused by (1) improper installation, (2) improper voltage, (3) lightning, (4) excessive sand or other abrasive material, (5) corrosion build-up due to excessive chemical content or (6) uncontrollable acts of god. Any modification of the original equipment will also void the warranty. We will not be responsible for loss, damage or labor cost due to interruption of service caused by defective pumps, parts or systems. Barmesa Pumps will not accept charges incurred by others without our prior written approval.

This warranty is void if our inspection reveals the product was used in a manner inconsistent with normal industry practice and/or our specific recommendations. The purchaser is responsible for communication of all necessary information regarding the application and use of the product. UNDER NO CIRCUMSTANCES WILL WE BE RESPONSIBLE FOR ANY OTHER DIRECT OR CONSEQUENTIAL DAMAGES, INCLUDING BUT NOT LIMITED TO TRAVEL EXPENSES, CONTRACTOR FEES, UNAUTHORIZED REPAIR SHOP EXPENSES, LOST PROFITS, LOST INCOME, LABOR CHARGES, DELAYS IN PRODUCTION, IDLE PRODUCTION, WHICH DAMAGES ARE CAUSED BY ANY DEFECTS IN MATERIAL AND/OR WORKMANSHIP AND/OR DAMAGE OR DELAYS IN SHIPMENT. THIS WARRANTY IS EXPRESSLY IN LIEU OF ANY OTHER EXPRESS OR IMPLIED WARRANTY. No rights extended under this warranty shall be assigned to any other person, whether by operation of law or otherwise, without our prior written approval.

IMPORTANT!

If you have a claim under the provision of the warranty, contact Barmesa Pumps or your authorized Barmesa Pumps Distributor:
warranty@barmesapumps.com
www.barmesapumps.com

